



**PRECISION**  
PERFECTLY  
SHAPED

# HIGH PRECISION DEEP DRAWN PARTS ALSO PUNCHED AND BENT PARTS

... FOR THE AUTOMOBILE-, ELECTRONICS- AND CONSTRUCTION INDUSTRIES ARE JUST SOME OF THE PRODUCTS MANUFACTURED BY SIXT GMBH.



**Location D-Magstadt**



**Location CZ-Jihlava**

**Sixt has a great legacy of 65 years experience in forming technology and tool making.**

Since 1999 we have expanded and set up a new branch in the Czech Republic. Our in-house engineered tool shop is equipped with all machines for the production of stamping and forming tools. Our delivery program is completed by the assembly of component groups and vibratory grinding as well as the cleaning of parts. We collaborate with reliable, long-term partners, to extend our offer on a wide variety of surface treatments. Our machinery includes presses up to 1.000 t press force, with which we process all material grades up to 6 mm thickness.

# CONSULTANCY, DESIGN ENGINEERING & TOOLMAKING

FROM PRODUCT DEVELOPMENT THROUGH TO ASSEMBLY.  
WE'RE WITH YOU EVERY STEP OF THE WAY

**Using forming analyses, the forming process can be defined and configured in advance.**

Based on these definitions, the tool is designed in CAD and subsequently manufactured according to this data.

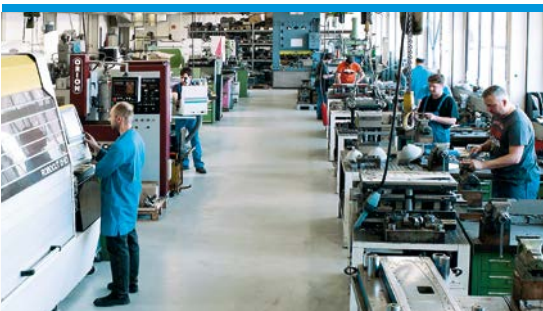

## IN OUR TOOL SHOP...

we manufacture tools, equipment and prototypes to meet your high quality standards.

- Manufacturing of stamping and forming tools, progressive-, deep drawing- and transfer tools
- Tool maintenance
- Full setup for tools up to 2200x800 mm
- All common CAD formats can be handled



# OUR PRODUCTION...

...has an extensive fleet of machinery for manufacturing punched, bent and deep drawn parts for all sectors.

We process strip material of all grades with a thickness from 0,1 to 6 mm and a bandwidth up to 800 mm.

## Machinery:

- Automated punching presses (500 – 8.000kN)
- Deep drawing presses (400 – 10.000kN)
- Transfer presses (5.000 – 8.000kN)
- Loading presses (400 – 10.000kN)
- Multiple-die presses (500 – 3.600kN)
- Plastic injection machine (3.000kN/500g)



## ASSEMBLY

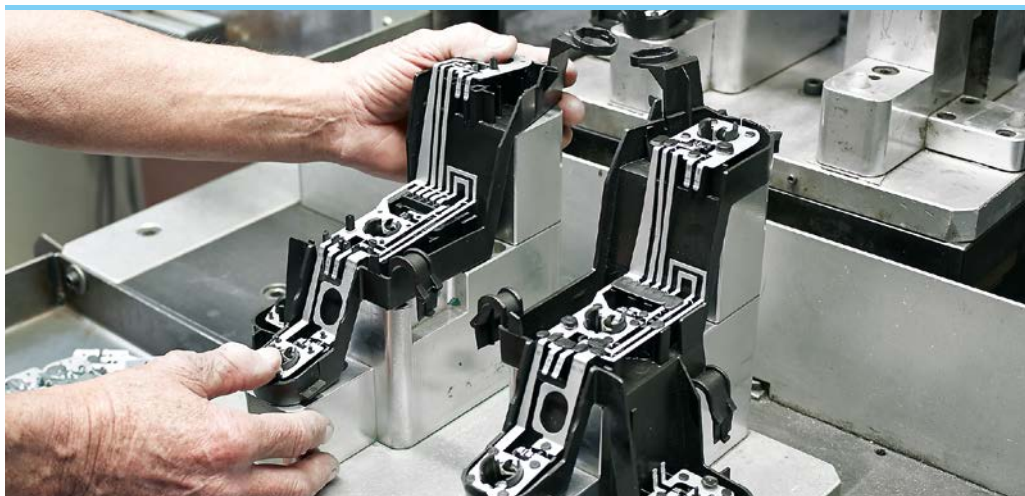

Our product range is completed by a variety of assembly techniques for the manufacture of assemblies (e.g. spot, pressure welding, tumble riveting, hot riveting).

# SURFACE TREATMENT



## SURFACE TREATMENT

In collaboration with our qualified partners we can also offer virtually all types of surface treatments.

### IN-HOUSE

- Tumbling/barrel finishing
- Parts cleaning
- Annealing

### EXTERNAL

- Galvanising
- Cathodic painting, powder coating
- Chrome plating
- Polishing
- Hardening and annealing

## OUR QUALITY MANAGEMENT SYSTEM IS CERTIFIED ACCORDING TO ISO 9001.

- Compliance with automobile industry standards (VDA, AIAG)
- Ongoing development of the management system (from 1998: ISO 9001, from 2002: VDA6.1, from 2010: ISO/TS16949)
- Modern CAQ system
- Wide range of measuring/testing methods (3D measuring machine, digital measurement projector, Faro 3D scanner, contour measuring machine, measuring microscope, camera system for 100 % testing)

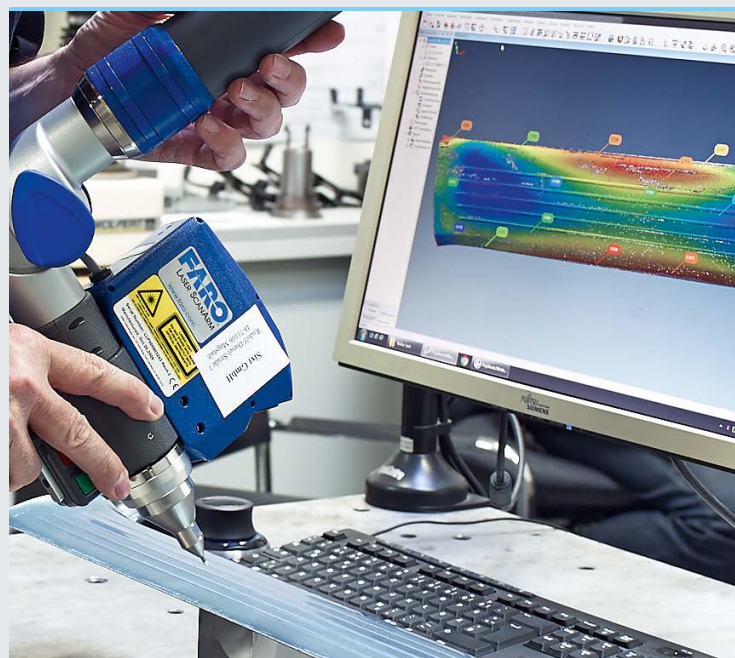

# PUNCHED- AND BENT PARTS



WE MANUFACTURE  
**PRECISION PUNCHED  
AND BENT PARTS...**

on automated punching presses,  
eccentric presses and hydraulic  
presses capable of delivering  
pressing forces of up to  
10.000kN.

## EXAMPLE APPLICATIONS

- Strippers for document shredders
- Clutch rings for automatic transmissions
- Fittings and fastenings for the construction industry

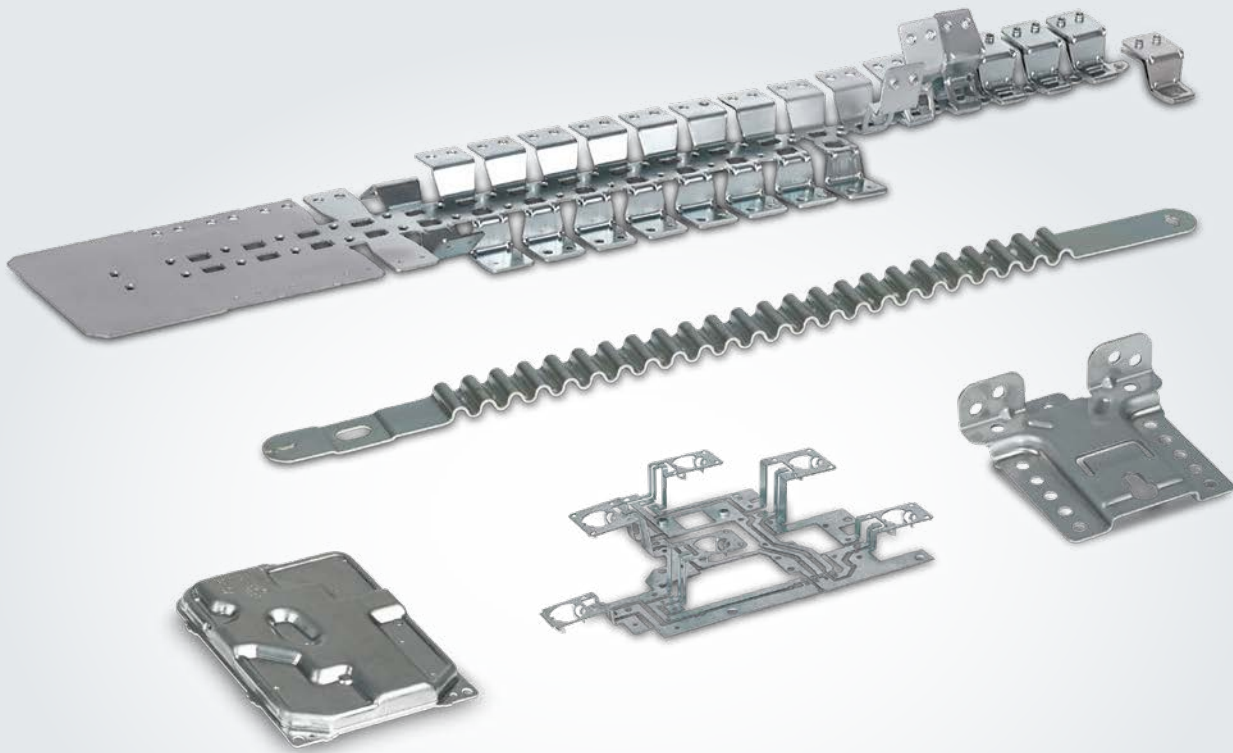

WITH HIGH-PRECISION  
**PROGRESSIVE TOOLS**  
we manufacture complex,  
finished-falling parts.

#### EXAMPLE APPLICATIONS

- Lock strikers for passenger cars
- Heat sinks for electronic components
- Conductor paths for rear vehicle light clusters
- Damping spring
- Fixtures for heat exchangers + air filters



# DEEP DRAWN PARTS



## WE MANUFACTURE...

for more than 40 years deep drawn parts on hydraulic triple-action presses using hydro-mechanical processes and pressing forces of up to 3150 kN. We also employ dual-action presses delivering up to 10.000 kN

## EXAMPLE APPLICATIONS

- Headlamp housings and retaining frames
- Water tanks for heat exchangers
- Cover caps for door closers
- Cover rollover bar for passenger cars
- Motor gear housings for windows





WITH OUR  
**MULTIPLE-DIE PRESSES**  
(up to 11 stages) and with our  
**TRANSFER PRESSES**  
we manufacture high-precision  
and elaborately formed parts.

#### EXAMPLE APPLICATIONS

- Headlamp reflectors
- Lens holders for headlamps
- Engine parts

# SUBASSEMBLIES

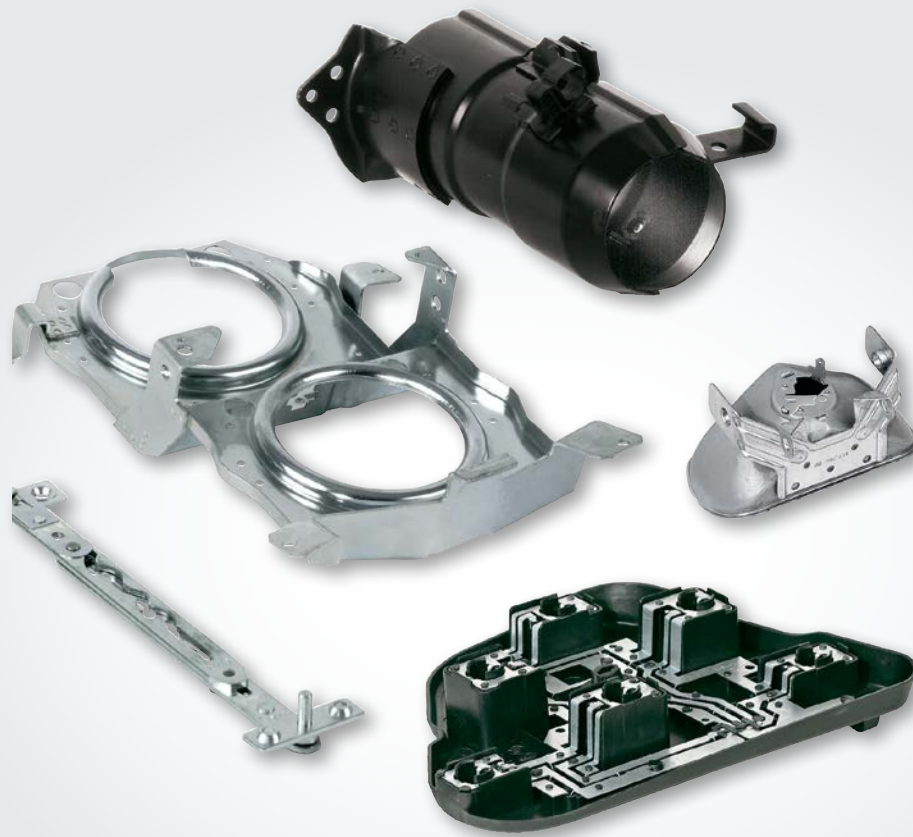

## WE ASSEMBLE...

our components together with parts supplied by the customer into simple and complex subassemblies and systems, creating packaged, ready-for-sale products.

## EXAMPLE APPLICATIONS

- Vehicle components
  - Headlamps
  - Headlamp retaining frames and surrounds
  - Bulb sockets
  - Boot lock strikers
  - Oil filter valves
  - Door sill trims
  - Loading sills
  - Bulb mounts for rear vehicle light clusters
- Construction and window fittings
- Furniture hinges
- Metal/plastic composite parts

# DEKORATIVE PARTS



WE MANUFACTURE **ALUMI-  
NIUM-** AND **STAINLESS  
STEEL DECORATIVE  
TRIM PARTS...**

and assemble them with the plastic part to create a ready-to-install subassembly

## EXAMPLE APPLICATIONS

- ② Door sill trims for passenger cars
- ② Boot loading sills



### **Sixt GmbH**

Rudolf-Diesel-Strasse 1  
71106 Magstadt  
DEUTSCHLAND  
Tel.: +49-(0)7159-94483-0  
Fax: +49-(0)7159-94483-21  
E-Mail: info@sixt-gmbh.de

[www.sixt-gmbh.de](http://www.sixt-gmbh.de)



### **Sixt Umformtechnik s.r.o.**

Herolticka 10  
58601 Jihlava  
TSCHECHIEN  
Tel.: +420-567-1216-18  
Fax: +420-567-1216-55  
E-Mail: info@sixt-sro.cz

[www.sixt-sro.cz](http://www.sixt-sro.cz)